

Gareth Fry

Mobile: +44 7973 352669

Fax: +44 7970 640 361

email: garethfry@hotmail.com

Chris Shutt

Mobile: + 44 7932 671 466

email: CShutt@  
NationalTheatre.org.uk

---

## Sound specifications MNEMONIC - Complicite VENUE to provide:

No. of Item

### **Music & Vocal system - see Coverage plans for useage**

Full-range stereo proscenium system:

- 4x - 6x d&b E9 loudspeaker's with appropriate controller/amplifier's and flying hardware  
(quantity depends on auditorium size)
- 2 x d&b B1 sub-bass

Vocal Cluster:

- 4 x d&b C6 loudspeaker's with appropriate controller/amplifier's and flying hardware to  
rig in 2 x 2 formation

Front Fills:

- 4 x d&b E3 loudspeaker's with appropriate controller/amplifier's, **each with seperate feeds**

Under-Balcony Delay speaker's:  
as necessary

### **FX speakers**

- 2 upstage speakers & amplifiers, eg d&b E9's, Meyer UPA's with appropriate  
controller/amplifier's (flying hardware not required)

### **Surround system - see Coverage plans for useage**

- 1 Surround Sound System: consisting of d&b E3 or Meyer UPM loudspeakers

**Please note: We are open to suggestions for substitutions, but these must be approved by either Gareth Fry or Chris Shutt at least 2 weeks in advance of the fit-up.**

### **Mic.s**

- 2 Sennheiser MKH416 rifle mic's:  
with sprung clips with hook clamp mounting
- 3 x Crown PCC160's, with 1 spare XLR-Lemo cable
- 8 x UHF Radio mic **receivers**, diversity system with switchable frequencies and:  
- 1 x 10m and 1 x 20m antennae cable
- 6 x Lavalier UHF Radio mic **transmitters**, with switchable frequencies and:  
- 5 x Sennheiser MKE-2 mic capsule (black)  
- 1 x XLR adaptor, to allow wired mic. to be connected to transmitter  
- 2 x spare Sennheiser MKE-2 mic capsule (black)  
- spare transmitter aerial's  
- tie-clip adaptor's etc not required  
- 1 **battery** per show or per 2 tech sessions
- 2 x Handheld UHF Radio mic **transmitters**, with switchable frequencies and:  
- dynamic capsule  
- 1 **battery** per show or per 2 tech sessions

## **Cable**

Complicite will provide cable to connect the Mixer to the outboard equipment. Multi's, speaker cable, mains cable, etc should be provided by the venue to connect the system as detailed in the attached schematic & layout plans.

## **Mains**

- 1 APC-1400 Smart UPS, or equivalent
- 1 Furman power conditioner

The system should be connected to a dedicated sound mains supply, ie not used for anything other than sound equipment. Mains distribution should be provided as necessary. The FOH Mix position will operate off a single mains feed, terminated at the Mixer Power Supply Rack, which then has a 20m run to the Mix Position.

## **Comms**

Hard wired comms system on 1 circuit (single muff): Sound, LX, Up Stage Left, Up Stage Right, Down Stage Left, Down Stage Right, Up Stage Centre, Flys.

Please note: all equipment supplied must be of professional audio quality, in good working order and constant for the duration of the run. We reserve the right to reject any item supplied, if it is deemed to be of inadequate quality, unsuitable for it's supposed purpose or in poor condition whether of a cosmetic or electrical nature. Unless otherwise specified, all speakers, rigging accessories, mic. stands etc must be matt black in colour.

# VENUE to hire from Complicite:

## **Mixer**

- 1 Amek Recall **RL** Mixer (40 frame version)  
- with 2 PSU's, with cable (20m) to site PSU's away from mix position

## **Outboard**

- 3 12u racks, forming stand for mixer, containing:
  - 1 Lexicon PCM-81
  - 2 Lexicon MPX1's
  - 3 BSS Soundweb 9088 configurable matrix, with XLR patchbay
  - 1 PC laptop running Showtime software
  - 2 Denon 1050 MD's
  - 2 Sony MD's
  - 1 mm productions relay controller
  - 2 Akai s6000 sampler's, 256Mb RAM, 9gig hard drive
  - 1 Denon CD player
  - 2 PC computer's running GType for Windows and Soundweb Designer
  - 2 mains distro

We have found in the past that as most of this equipment is highly specialised and not able to be substituted with other models, it is often both difficult and expensive to hire this equipment locally. Therefore we intend to hire/buy this equipment in the UK and tour it with us, on the condition that the venue agree's to pay Complicite a mutually agreed fee to cover Complicite's costs in obtaining the equipment. We feel this arrangement will mutually benefit both Complicite and each venue.

Thanks,

Gareth Fry & Chris Shutt  
Sound Designers

version: GF/16/5/2001

# MIX POSITION PLAN

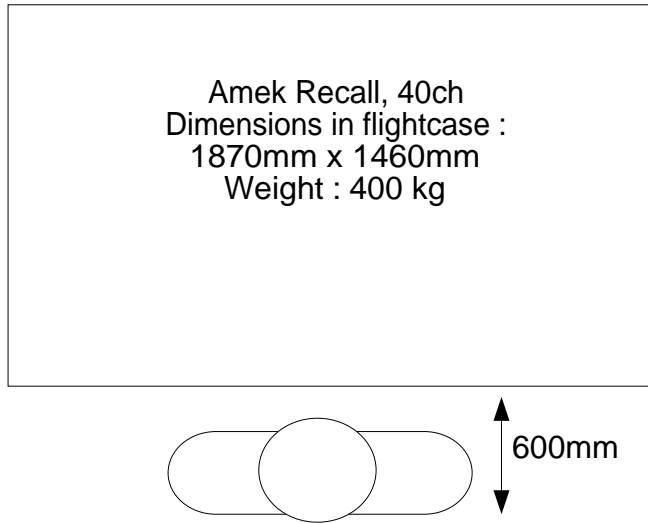

**PLEASE NOTE: WE REQUIRE AN AUDITORIUM MIX POSITION:  
THIS MUST BE A LEVEL AREA OF 2m x 2m. ALL VENUES ARE REQUESTED TO  
CONFIRM WITH THEIR BOX OFFICE TO ENSURE THAT, IF NECESSARY, THE  
REQUIRED SEATING HAS BEEN TAKEN OFF SALE**

## MIX POSITION RACKING

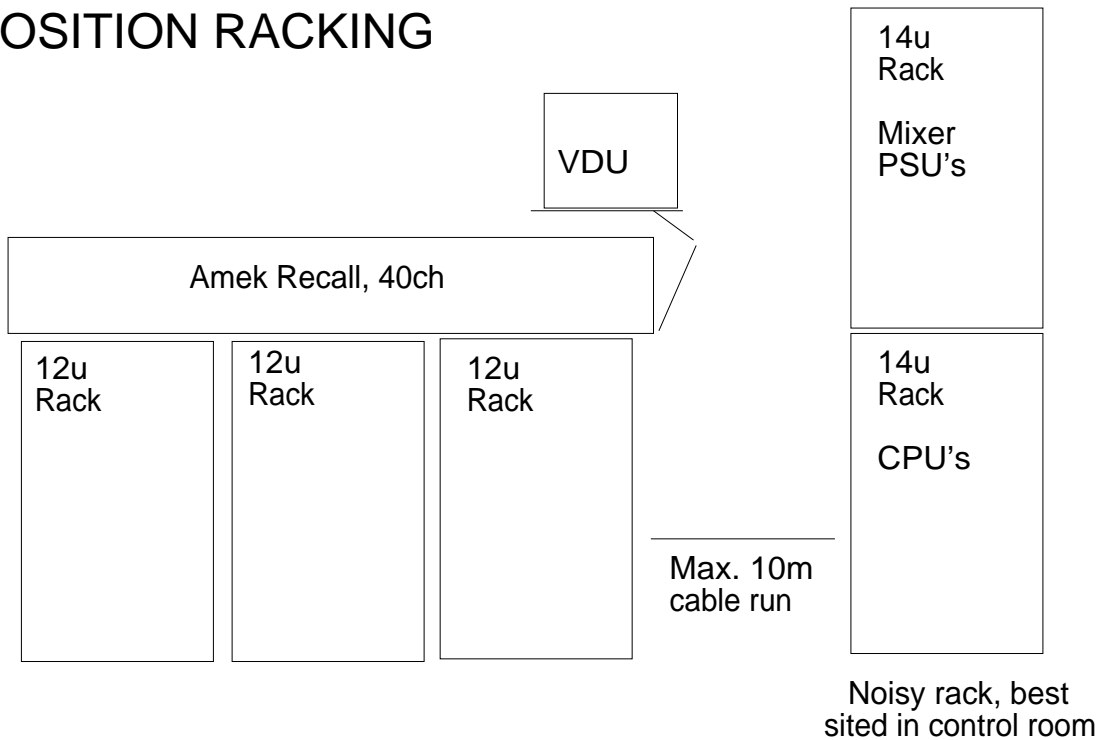

# Audio schematic for Mnemonic

## Mixer inputs

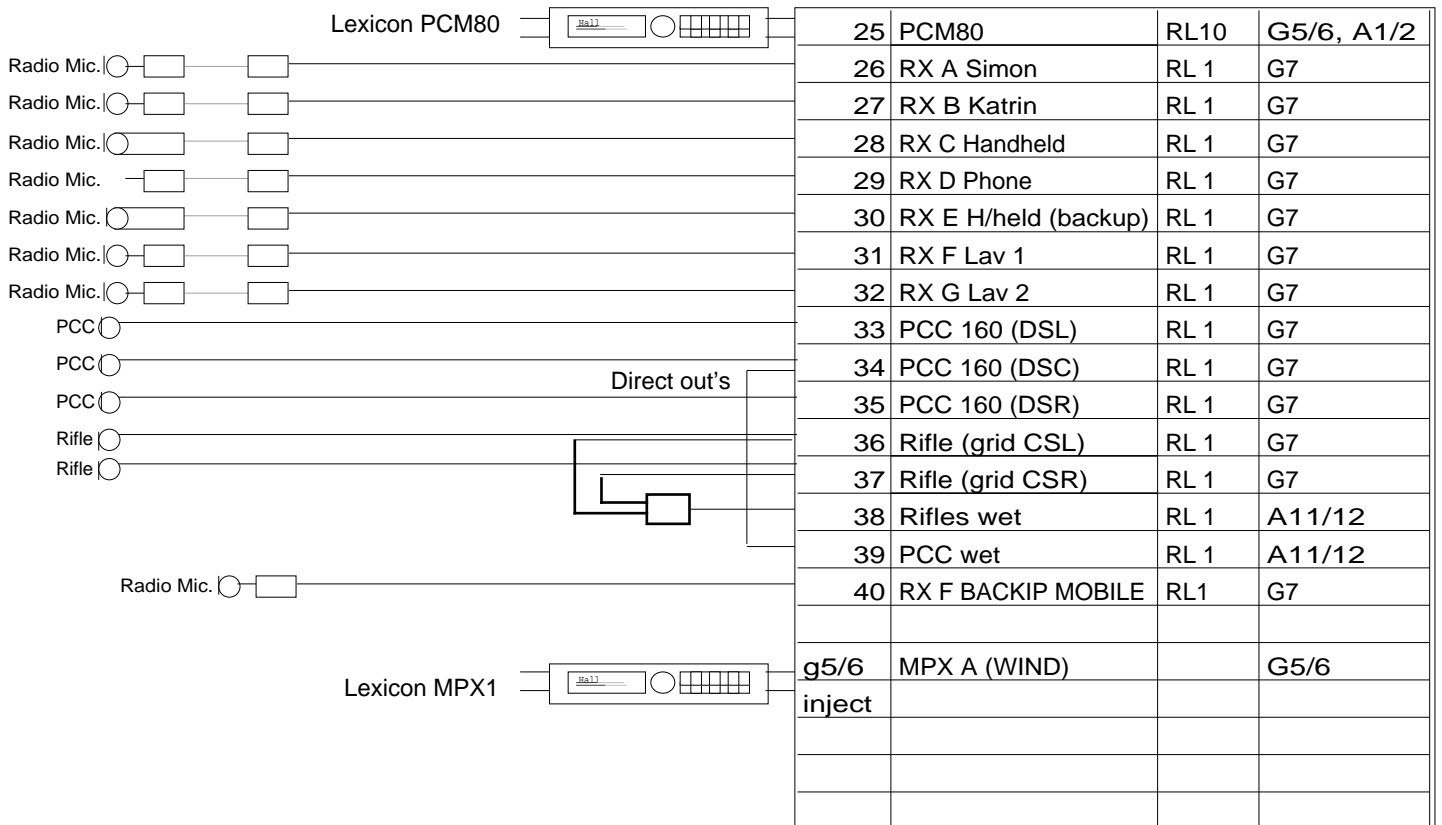
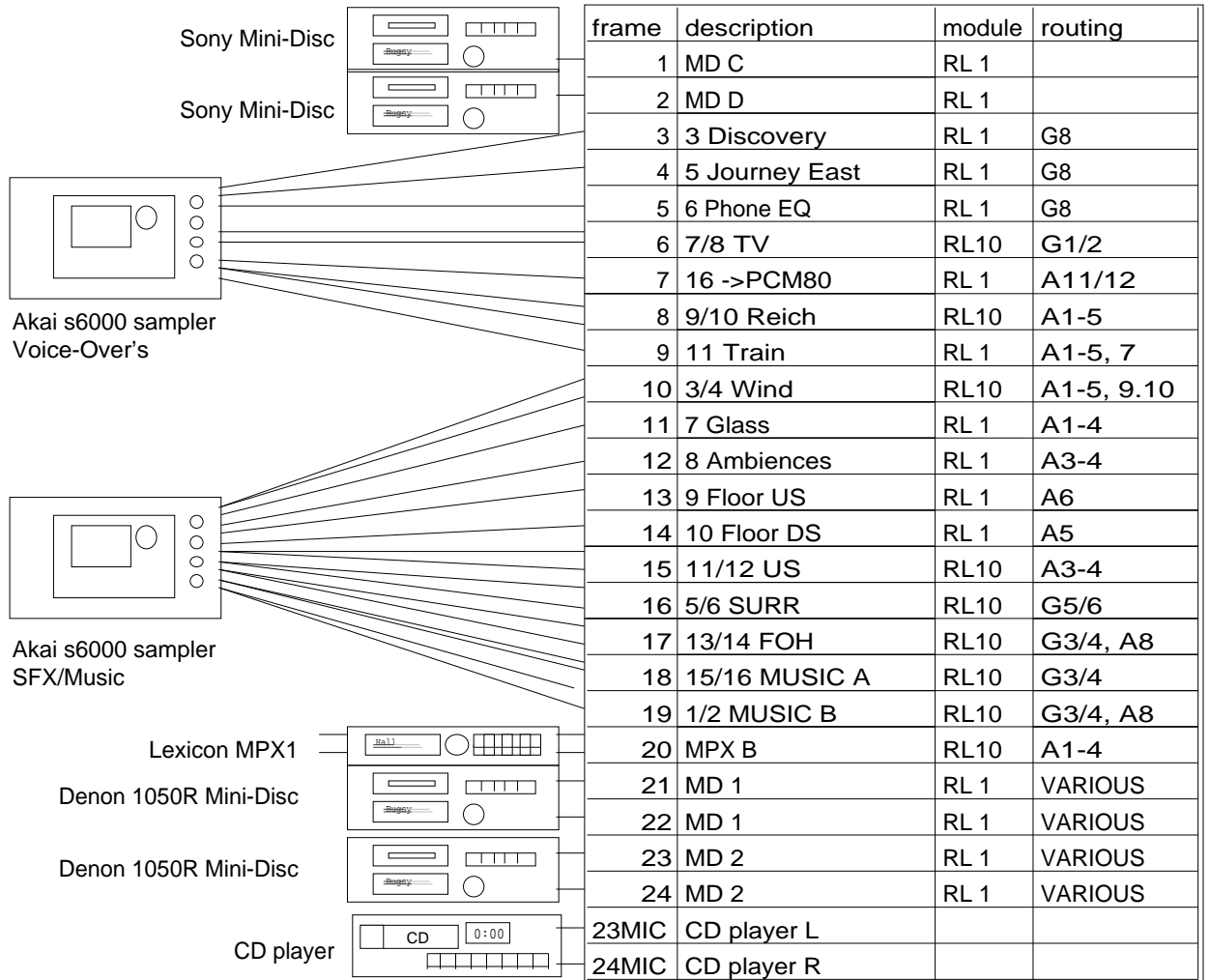

# Mixer outputs

Matrix 8	
Matrix 7	
Matrix 6	
Matrix 5	
Matrix 4	
Matrix 3	
Matrix 2	
Matrix 1	
Aux 12	PCM80 L
Aux 11	PCM80 R
Aux 10	MPX A WIND
Aux 9	MPX A WIND
Aux 8	MPX B
Aux 7	Subs
Aux 6	US E3
Aux 5	DS E3
Aux 4	Upstage L
Aux 3	Upstage R
Aux 2	FOH L
Aux 1	FOH R
grp 7	MIC'S VOX
grp 8	PB VOX
grp 5	SURR L
grp 6	SURR R
grp 3	MUSIC L
grp 4	MUSIC R
grp 1	TV L
grp 2	TV R
Mix L	sp1
Mix R	sp2
VCA 1	WIND
VCA 2	GLASS
VCA 3	TRAIN
VCA 4	REICH
VCA 5	Sleepless night
VCA 6	WET FLOATS
VCA 7	
VCA 8	VO'S

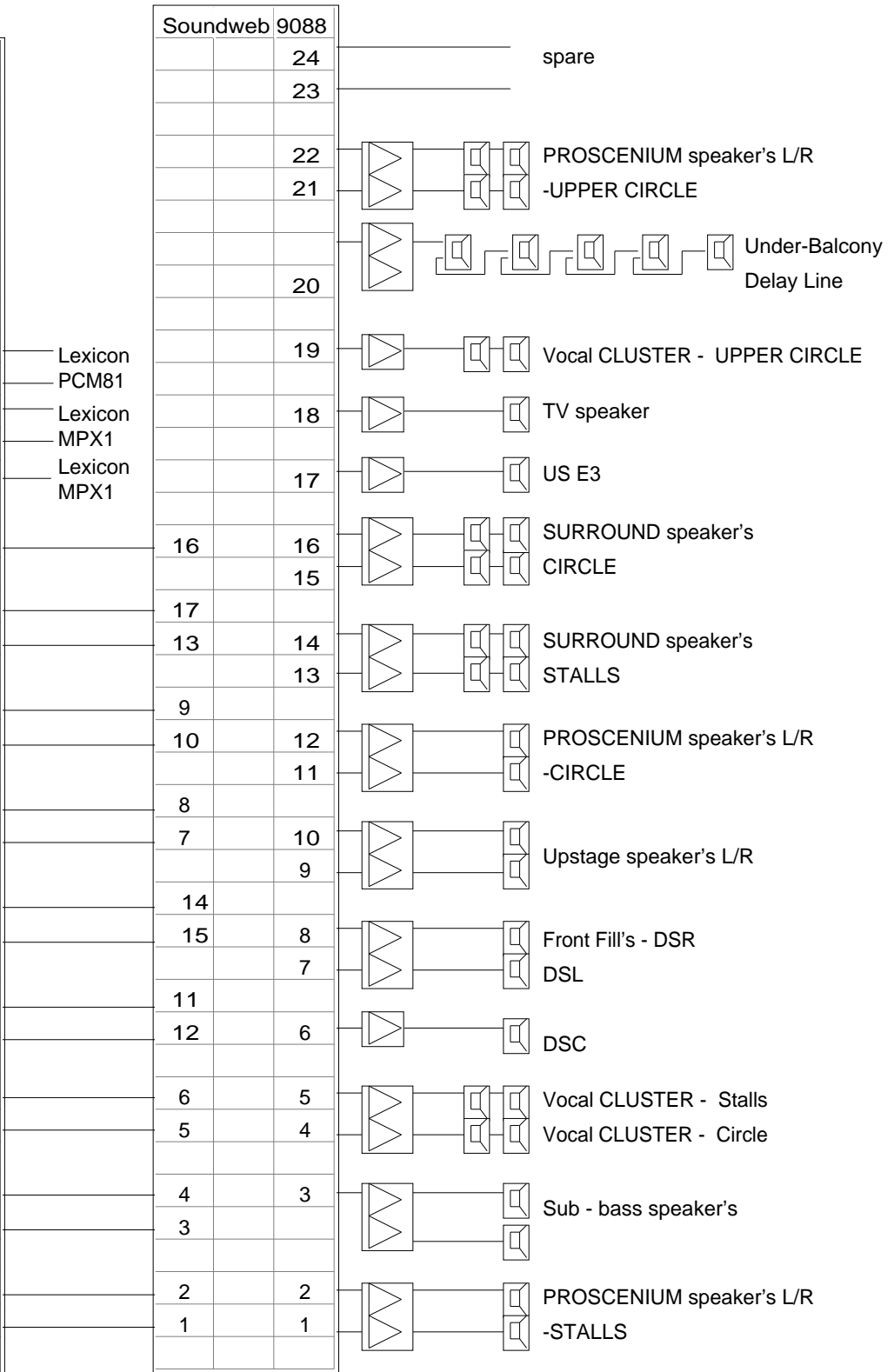

<p><b>Show:</b>  <b>Venue:</b>  <b>For:</b>  <b>Sound designer:</b>  <b>Production Sound Engineer:</b></p>	<p><b>Mnemonic</b>  <b>2002 tour</b>  <b>Theatre de Complicite</b>  <b>Chris Shutt</b>  <b>Gareth Fry</b>  <b>+44 7973 352669</b>  <b>garethfry@hotmail.com</b></p>
--	---

# Data schematic

## Mnemonic - Complicite

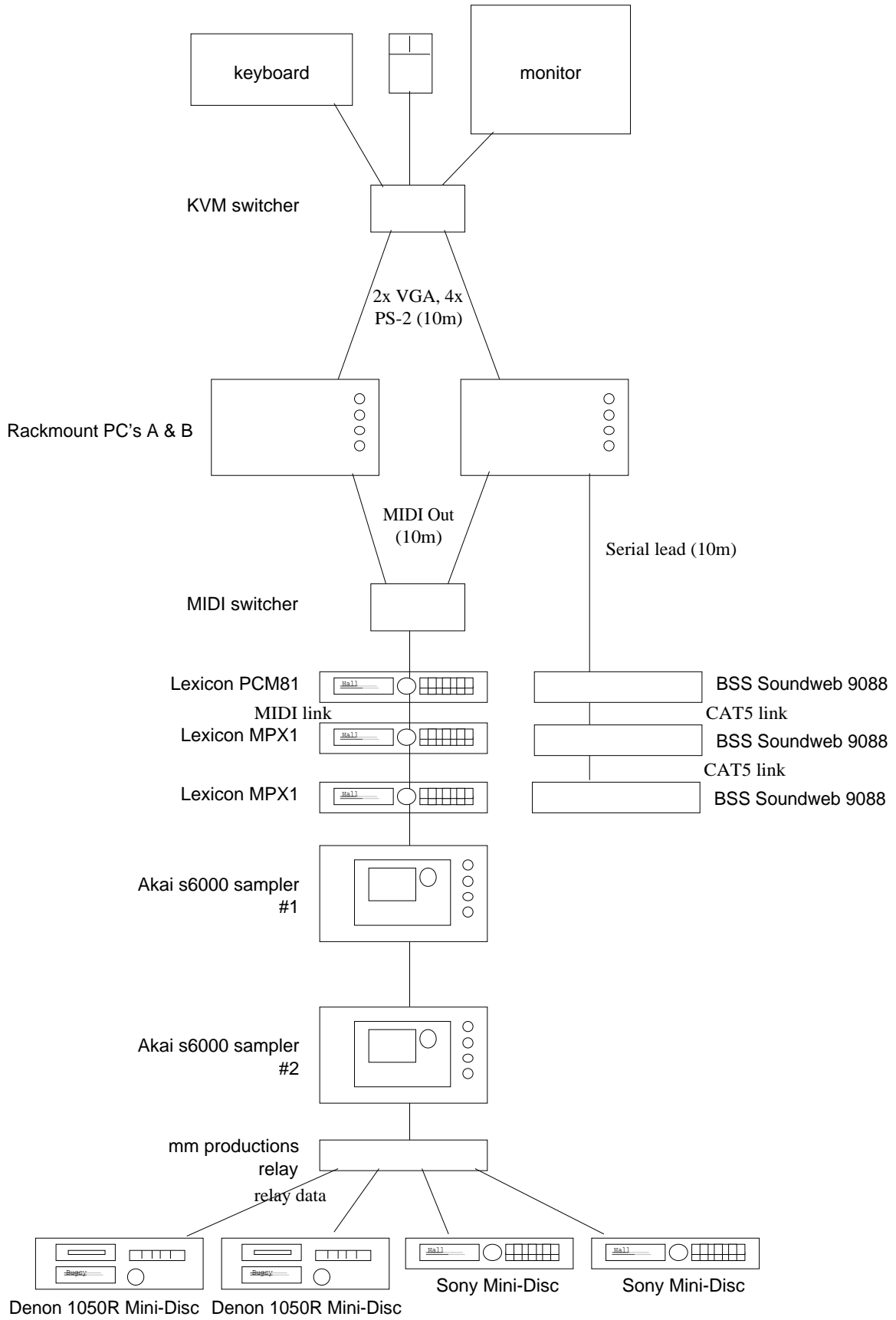

# Layout Mnemonic - Complicite

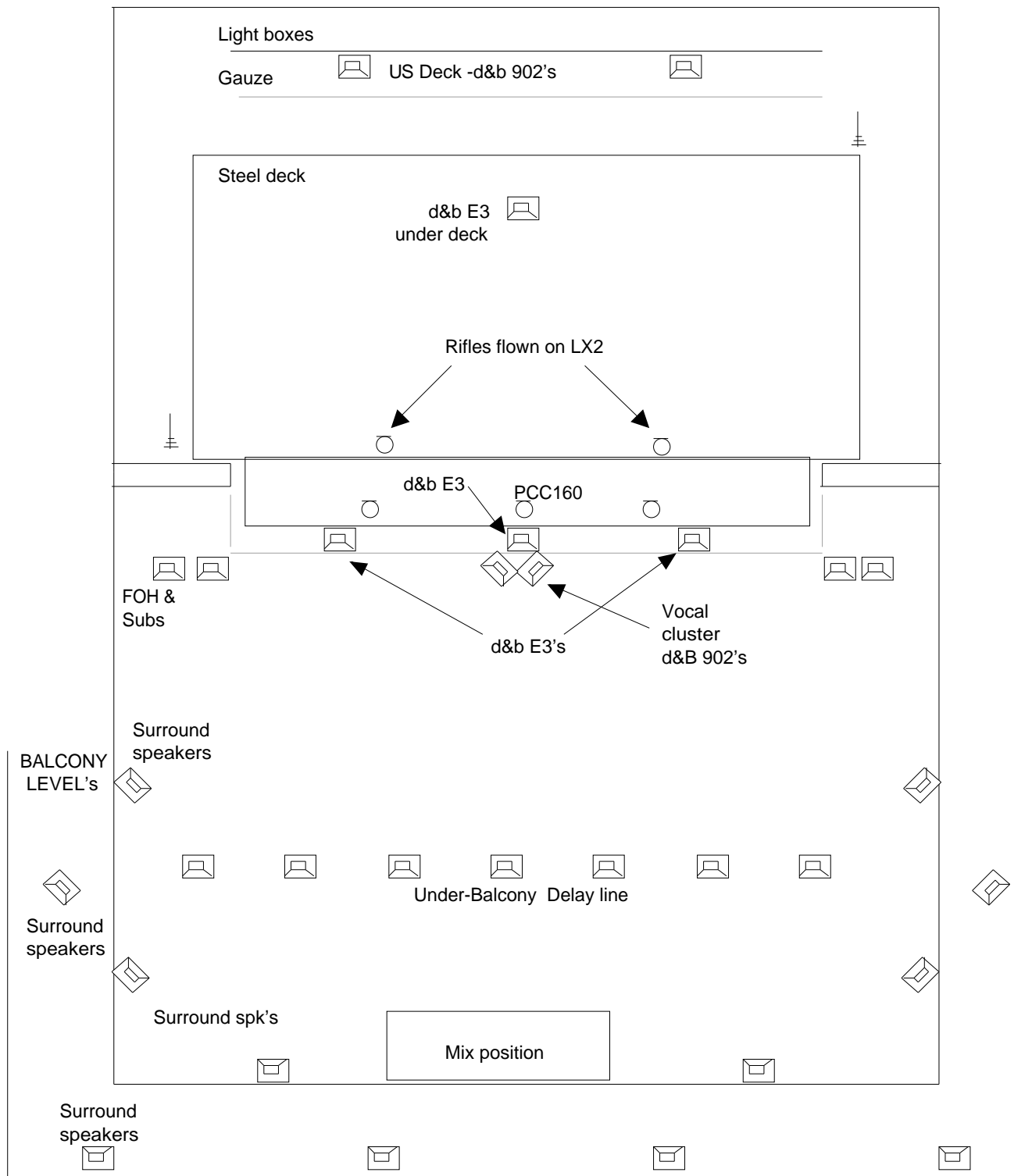

**Show:**  
**For:**  
**Venue:**  
**Sound designers:**  
 Chris Shutt  
 +44 793 267 1466  
 cshutt@nationaltheatre.org.uk

**Mnemonic**  
 Theatre de Complicite  
 2002 tour  
 Chris Shutt & Gareth Fry  
 Gareth Fry,  
 +44 7973 352 669  
 garethfry@hotmail.com

# MNEMONIC GENERIC SYSTEM COVERAGE FOR 2-LEVEL AUDITORIUM

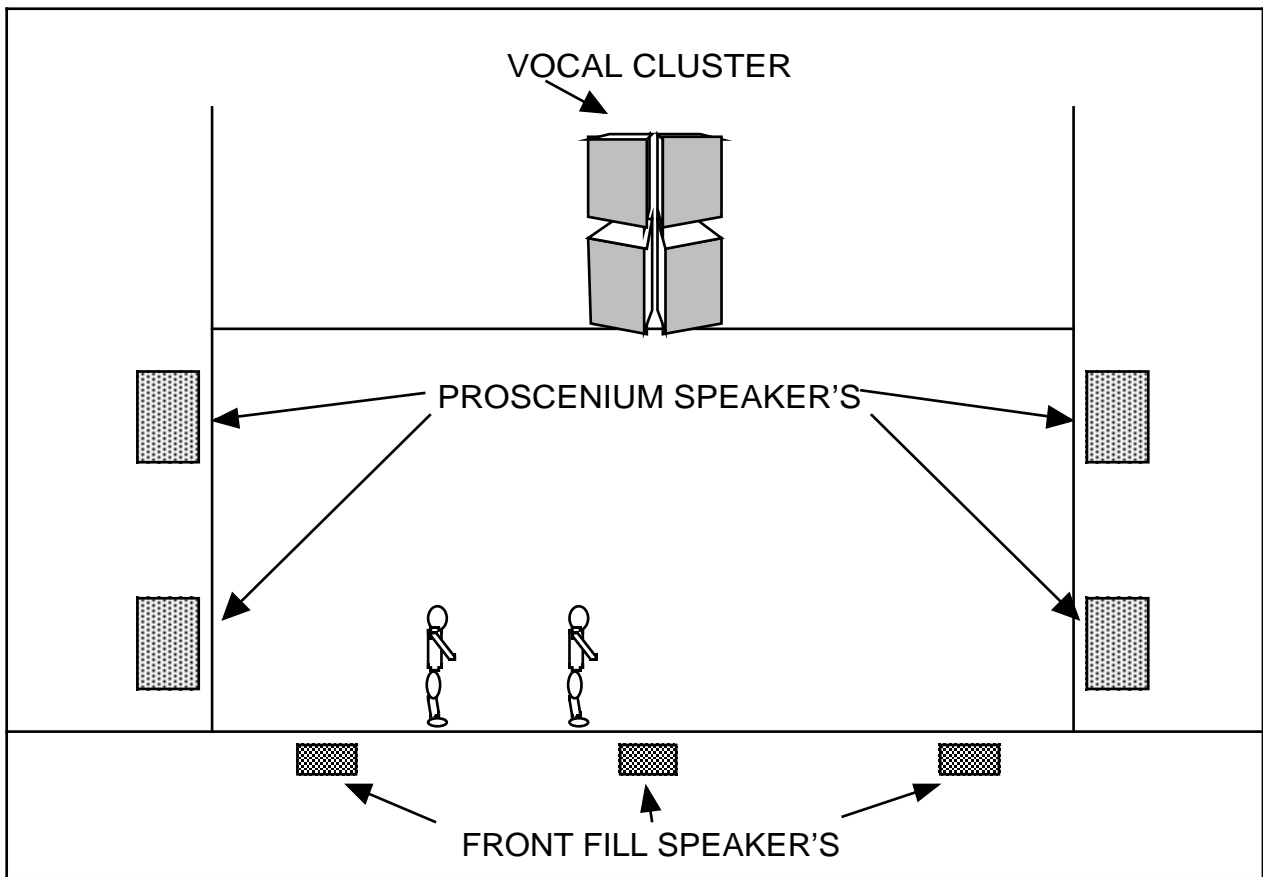

## VOCAL SYSTEM COVERAGE

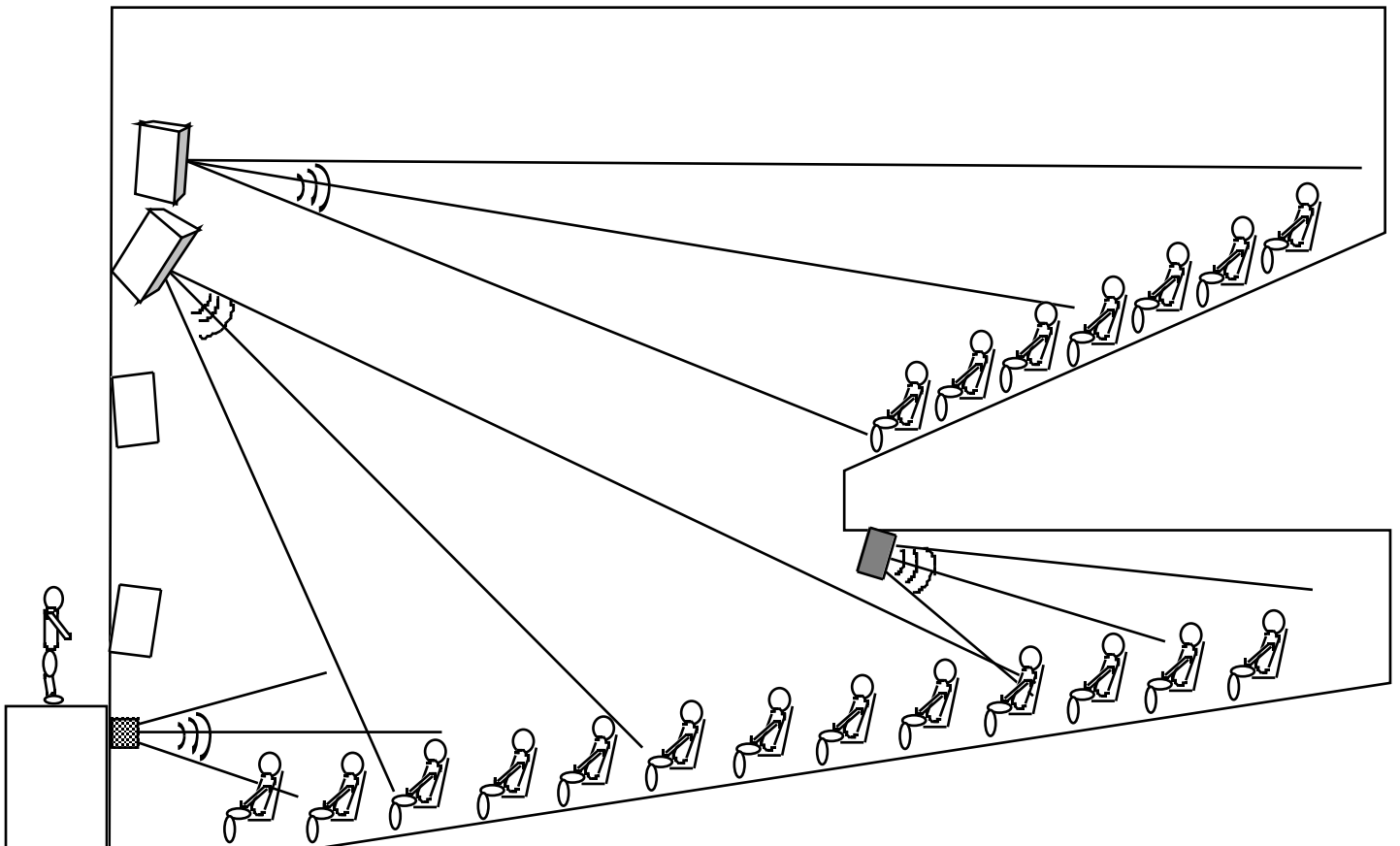

# MUSIC SYSTEM COVERAGE

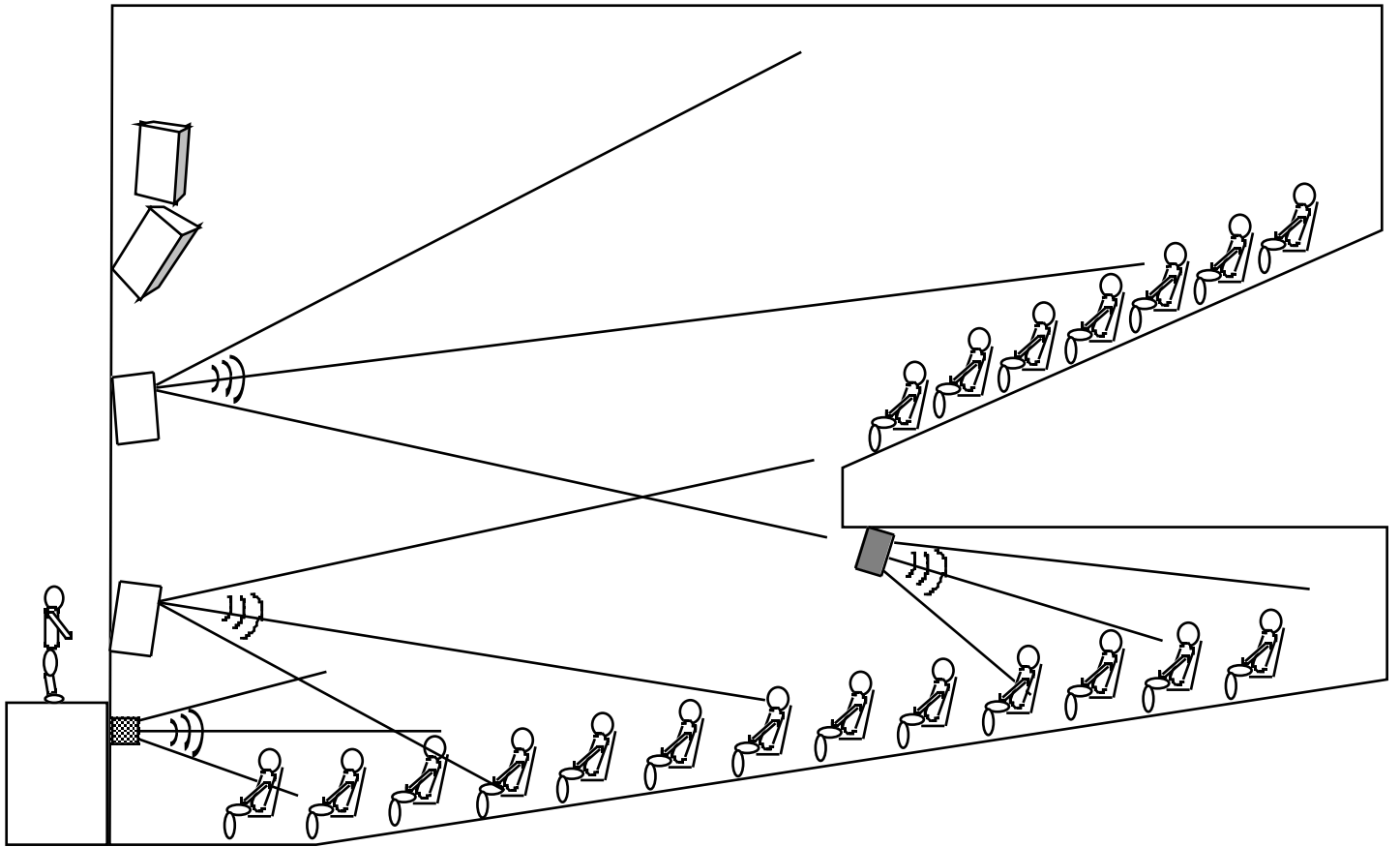

# SURROUND SYSTEM COVERAGE STALLS

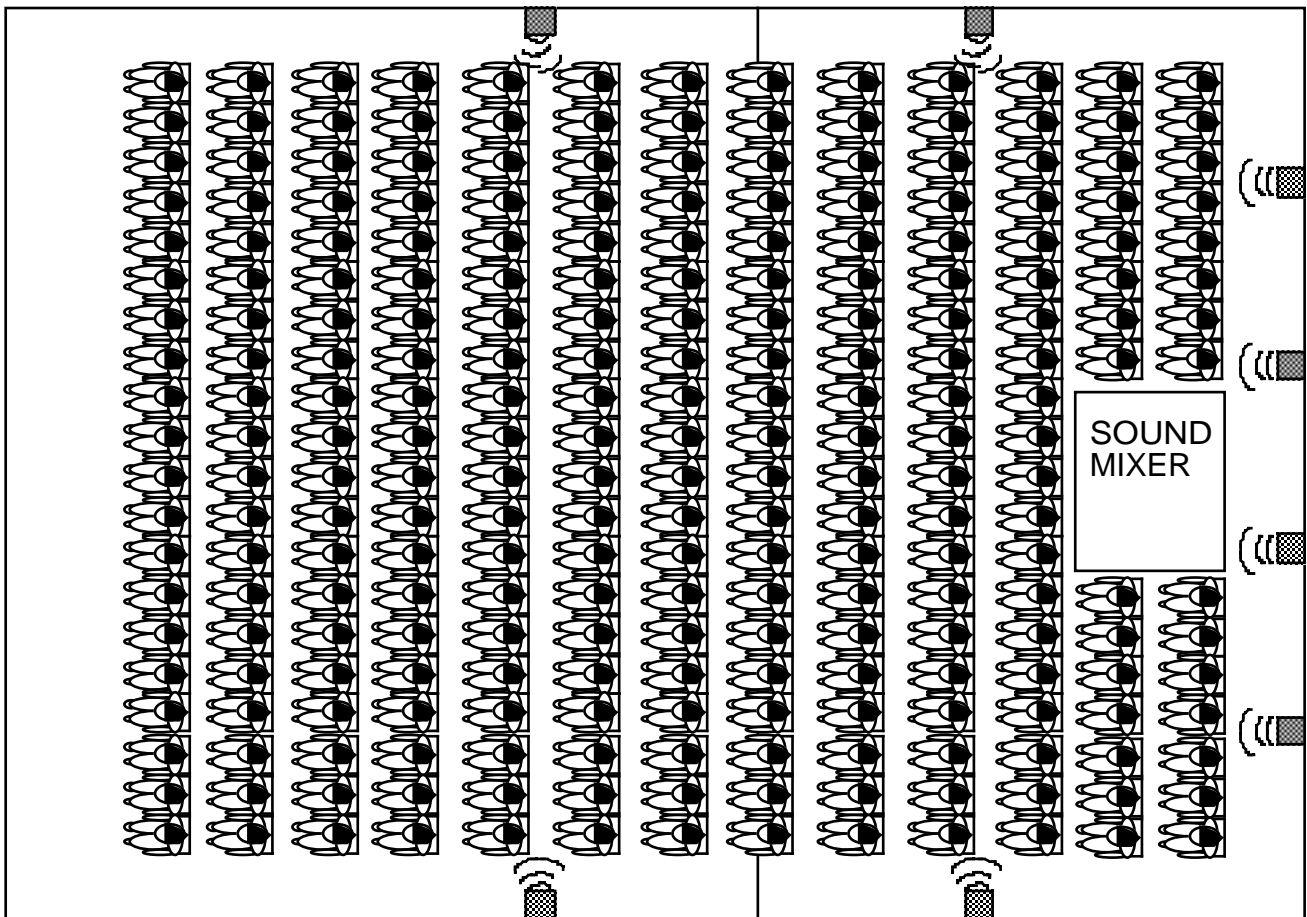

# SURROUND SYSTEM COVERAGE BALCONY

